



Aluminum electrolytic capacitors

Snap-in capacitors

Series/Type: B43661
Status: In development

Date: January 2025

Important note

This series is not yet released for mass production and subject to change. The products delivered are engineering samples, prototypes or pre-series products, which are not intended for commercial use in series products of the purchaser. The supplier assumes no warranty or liability. Any use is at the sole risk of the purchaser.

General-purpose grade capacitors
Applications

- Power supplies
- Frequency converters
- Uninterruptible power supplies
- Solar inverters
- Not for automotive applications unless otherwise specified

Features

- Ultra compact
- High reliability
- High ripple current capability
- RoHS-compatible

Construction

- Aluminum case, covered with PET sleeve without insulation sheet at the can bottom
- Snap-in solder pins to hold component in place on PC-board
- Minus pole marking on shrinking sleeve
- Minus pole not insulated from case
- Overload protection by pressure relief device on the base

Terminals

- 2 snap-in terminals, nominal length 4.5 mm
- 3 snap-in terminals, nominal length 4.5 mm
- 2 snap-in terminals, nominal length 6.3 mm



Preliminary data
Specifications and characteristics in brief

Rated voltage V_R Surge voltage V_S	450 V DC $1.10 \cdot V_R$ (15 ... 35 °C)			
Rated capacitance C_R Capacitance tolerance	500 ... 1300 μF $\pm 20\% \triangleq M$			
Dissipation factor $\tan \delta$ (20 °C, 120 Hz)	≤ 0.20			
Leakage current I_{leak} (5 min, 20 °C, reforming before measurement)	$I_{\text{leak}} \leq 0.3 \mu\text{A} \cdot \left(\frac{C_R}{\mu\text{F}} \cdot \frac{V_R}{V} \right)^{0.7} + 4 \mu\text{A}$			
Self-inductance ESL	Approx. 20 nH			
Useful life ¹⁾ 105 °C; V_R ; $I_{AC,R}$	> 3000 h	Requirements: $ \Delta C/C \leq 20\%$ of initial value $\tan \delta \leq 2$ times initial specified limit $I_{\text{leak}} \leq$ initial specified limit		
Vibration resistance test	To IEC 60068-2-6:2007, test Fc: Frequency range 10 ... 55 Hz, displacement amplitude 0.35 mm, acceleration max. 5 g, duration 3 × 2 h. Capacitor mounted by its body which is rigidly clamped to the work surface.			
Characteristics at low temperature	Max. impedance ratio at 100 Hz	V_R	450 V	475 V
		$Z_{-25\text{ °C}} / Z_{20\text{ °C}}$	10	10
		$Z_{-40\text{ °C}} / Z_{20\text{ °C}}$	20	20
IEC climatic category	To IEC 60068-1:2013: 25/105/56 (–25 °C/+105 °C/56 days damp heat test): The capacitors can be operated in the temperature range of –40 °C to +105 °C but the impedance at –40 °C must be taken into consideration.			
Sectional specification	IEC 60384-4:2016			

1) Refer to chapter “General technical information, 5 Useful life” on how to interpret useful life.

Preliminary data

Dimensional drawings

Snap-in capacitors with PET shrinking sleeve

“PET” marking on the sleeve. Pressure relief device on the base.

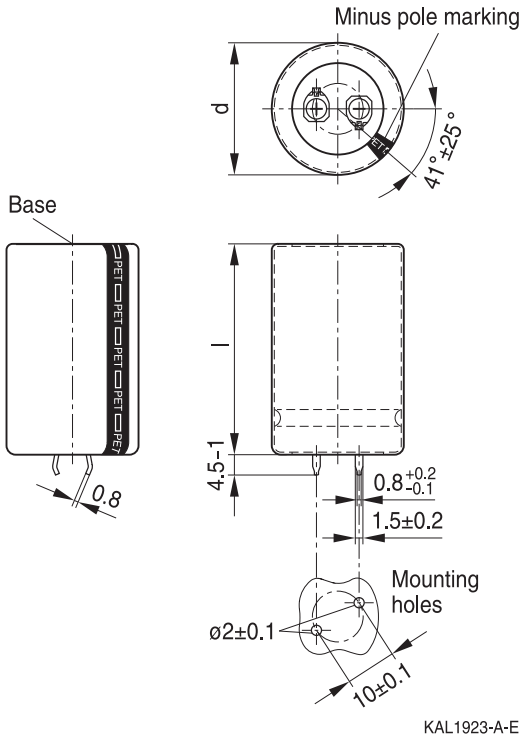

Snap-in terminals (2 terminals, 4.5 mm)

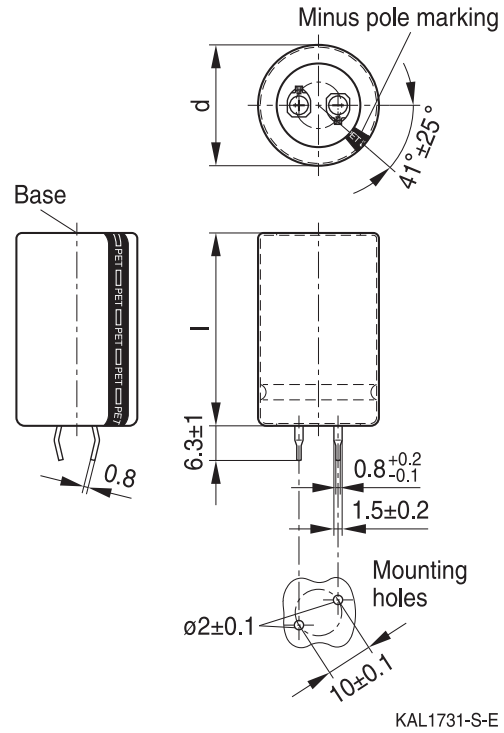

Snap-in terminals (2 terminals, 6.3 mm)

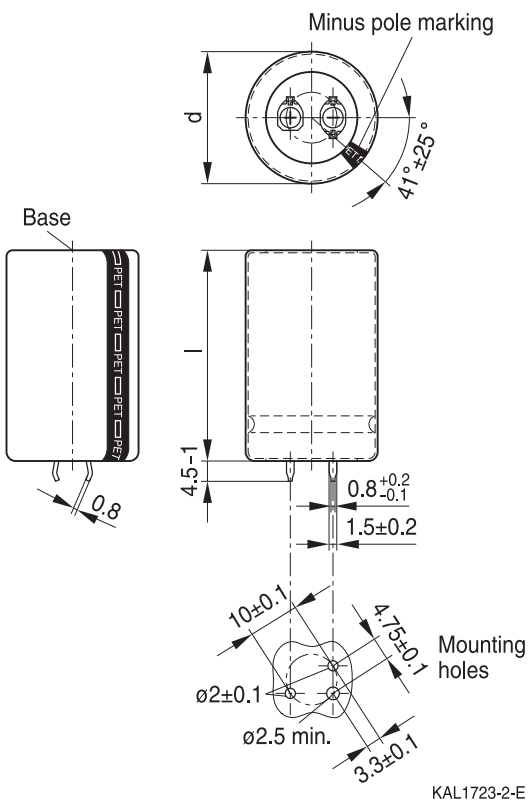

Snap-in terminals (3 terminals, 4.5 mm)

Preliminary data
Dimensions and packing units

Dimensions (mm)		Approx. weight (g)	Packing units (pcs.)
d +1	l +2.5/-2		
25.4	45	25	130
25.4	50	29	130
25.4	55	32	130
25.4	60	36	45
25.4	65	39	45
25.4	70	42	45

Dimensions (mm)		Approx. weight (g)	Packing units (pcs.)
d +1	l +2.5/-2		
30	45	41	80
30	50	46	80
30	55	53	80
30	60	58	60
30	65	64	60
30	70	69	60

Packaging of snap-in capacitors

For ecological reasons the packing is cardboard.

Ordering codes for terminal styles and insulation features

Identification in 3rd block of ordering code

Snap-in capacitors

Terminal version	Insulation PET sleeve
Snap-in terminals (2 terminals, 4.5 mm)	M*57
Snap-in terminals (3 terminals, 4.5 mm)	M*52
Snap-in terminals (2 terminals, 6.3 mm)	M*50

* Digit used for nominal capacitance indication.

Ordering examples:

B43661A5138M057 } snap-in capacitor with 2 pin terminals (4.5 mm) and PET sleeve

B43661A5138M052 } snap-in capacitor with 3 pin terminals and PET sleeve

Preliminary data
Overview of available types

The capacitance and voltage ratings listed below are available in different case sizes upon request. Other voltage and capacitance ratings are also available upon request.

V_R (V DC)	450
	Case dimensions d x l (mm)
C_R (μF)	
500	25.4 x 45
570	25.4 x 50
640	25.4 x 55
710	25.4 x 60
780	25.4 x 65 30 x 45
840	25.4 x 70
880	30 x 50
980	30 x 55
1090	30 x 60
1190	30 x 65
1300	30 x 70

Preliminary data
Technical data and ordering codes

C_R	Case	$I_{AC, R}$	Ordering code
120 Hz	dimensions	120 Hz	(composition see below)
20 °C	d × l	105 °C	
μF	mm × mm	A	
$V_R = 450$ V DC			
500	25.4 x 45	2.02	B43661A5507M05#
570	25.4 x 50	2.26	B43661A5577M05#
640	25.4 x 55	2.50	B43661A5647M05#
710	25.4 x 60	2.56	B43661A5717M05#
780	25.4 x 65	2.78	B43661A5787M05#
780	30 x 45	2.30	B43661B5787M05#
840	25.4 x 70	2.97	B43661A5847M05#
880	30 x 50	2.55	B43661A5887M05#
980	30 x 55	2.80	B43661A5987M05#
1090	30 x 60	3.07	B43661A5108M95#
1190	30 x 65	3.32	B43661A5118M95#
1300	30 x 70	3.58	B43661A5138M05#

Composition of ordering code

#	=	Terminal style
7	=	snap-in terminals (2 terminals, 4.5 mm)
2	=	snap-in terminals (3 terminals, 4.5 mm)
0	=	snap-in terminals (2 terminals, 6.3 mm)

Useful life¹⁾:

For useful life calculations, please use our web-based "AlCap Useful Life Calculation Tool", which can be found on the Internet under the following link:

www.tdk-electronics.tdk.com/en/alcap

The "AlCap Useful Life Calculation Tool" provides calculations of useful life as well as additional data for selected capacitor types under operating conditions defined by the user.

In addition, it is possible to calculate useful life expectancies based on temperatures measured by the user in the application.

1) Refer to chapter "General technical information, 5 Useful life" on how to interpret useful life."

Cautions and warnings

Personal safety

The electrolytes used have been optimized both with a view to the intended application and with regard to health and environmental compatibility. They do not contain any solvents that are detrimental to health, e.g. dimethyl formamide (DMF) or dimethyl acetamide (DMAC). Furthermore, some of the high-voltage electrolytes used are self-extinguishing.

As far as possible, we do not use any dangerous chemicals or compounds to produce operating electrolytes, although in exceptional cases, such materials must be used in order to achieve specific physical and electrical properties because no alternative materials are currently known.

We do, however, restrict the amount of dangerous materials used in our products to an absolute minimum.

Materials and chemicals used in our aluminum electrolytic capacitors are continuously adapted in compliance with the TDK Electronics Corporate Environmental Policy and the latest EU regulations and guidelines such as RoHS, REACH/SVHC, GADSL, and ELV.

MDS (Material Data Sheets) are available on our website for all types listed in the data book.

MDS for customer specific capacitors are available upon request.

Nevertheless, the following rules should be observed when handling aluminum electrolytic capacitors: No electrolyte should come into contact with eyes or skin. If electrolyte does come into contact with the skin, wash the affected areas immediately with running water. If the eyes are affected, rinse them for 10 minutes with plenty of water. If symptoms persist, seek medical treatment. Avoid inhaling electrolyte vapor or mists. Workplaces and other affected areas should be well ventilated. Clothing that has been contaminated by electrolyte must be changed and rinsed in water.

Product safety

The table below summarizes the safety instructions that must be observed without fail. A detailed description can be found in the relevant sections of separate file chapter "General technical information"

Topic	Safety information	Reference chapter "General technical information"
Polarity	Make sure that polar capacitors are connected with the right polarity.	1 "Basic construction of aluminum electrolytic capacitors"
Reverse voltage	Voltages of opposite polarity should be prevented by connecting a diode.	3.1.6 "Reverse voltage"
Mounting position of capacitors with screw or multi-pin terminals	Multi-pin capacitors with pressure relief vent on the can base must not be mounted with terminals facing up unless otherwise specified.	11.1 "Mounting positions of capacitors with screw or multi-pin terminals"
Robustness of terminals	The following maximum tightening torques must not be exceeded when connecting screw terminals: M5: 2.5 Nm M6: 4.0 Nm	11.2 "Mounting torques"
Mounting of single-ended capacitors	The internal structure of single-ended capacitors might be damaged if excessive force is applied to the lead wires. Avoid any compressive, tensile or flexural stress. Do not move the capacitor after soldering to PC board. Do not pick up the PC board by the soldered capacitor. Do not insert the capacitor on the PC board with a hole space different to the lead space specified.	11.3 "Mounting considerations for single-ended capacitors"
Soldering	Do not exceed the specified time or temperature limits during soldering.	11.5 "Soldering"
Soldering, cleaning agents	Do not allow halogenated hydrocarbons to come into contact with aluminum electrolytic capacitors.	11.6 "Cleaning agents"
Upper category temperature	Do not exceed the upper category temperature.	7.2 "Maximum permissible operating temperature"
Passive flammability	Avoid external energy, e.g. fire.	8.1 "Passive flammability"
Active flammability	Avoid overload of the capacitors.	8.2 "Active flammability"

Topic	Safety information	Reference chapter "General technical information"
Maintenance	Make periodic inspections of the capacitors. Before the inspection, make sure that the power supply is turned off and carefully discharge the capacitors. Do not apply excessive mechanical stress to the capacitor terminals when mounting.	10 "Maintenance"
Storage	Do not store capacitors at high temperatures or high humidity. Capacitors should be stored at +5 to +35 °C and a relative humidity of $\leq 75\%$.	7.3 "Shelf life and storage conditions"
		Reference chapter "Capacitors with screw terminals"
Breakdown strength of insulating sleeves	Do not damage the insulating sleeve, especially when ring clips are used for mounting.	"Screw terminals – accessories"

Display of ordering codes for TDK Electronics products

The ordering code for one and the same product can be represented differently in data sheets, data books, other publications, on the company website, or in order-related documents such as shipping notes, order confirmations and product labels. The varying representations of the ordering codes are due to different processes employed and do not affect the specifications of the respective products.

Detailed information can be found on the Internet under www.tdk-electronics.tdk.com/orderingcodes.

Symbols and terms

Symbol	English	German
C	Capacitance	Kapazität
C _R	Rated capacitance	Nennkapazität
C _S	Series capacitance	Serienkapazität
C _{S,T}	Series capacitance at temperature T	Serienkapazität bei Temperatur T
C _f	Capacitance at frequency f	Kapazität bei Frequenz f
d	Case diameter, nominal dimension	Gehäusedurchmesser, Nennmaß
d _{max}	Maximum case diameter	Maximaler Gehäusedurchmesser
ESL	Self-inductance	Eigeninduktivität
ESR	Equivalent series resistance	Ersatzserienwiderstand
ESR _f	Equivalent series resistance at frequency f	Ersatzserienwiderstand bei Frequenz f
ESR _T	Equivalent series resistance at temperature T	Ersatzserienwiderstand bei Temperatur T
f	Frequency	Frequenz
I	Current	Strom
I _{AC}	Alternating current (ripple current)	Wechselstrom
I _{AC,RMS}	Root-mean-square value of alternating current	Wechselstrom, Effektivwert
I _{AC,f}	Ripple current at frequency f	Wechselstrom bei Frequenz f
I _{AC,max}	Maximum permissible ripple current	Maximal zulässiger Wechselstrom
I _{AC,R}	Rated ripple current	Nennwechselstrom
I _{leak}	Leakage current	Reststrom
I _{leak,op}	Operating leakage current	Betriebsreststrom
l	Case length, nominal dimension	Gehäuselänge, Nennmaß
l _{max}	Maximum case length (without terminals and mounting stud)	Maximale Gehäuselänge (ohne Anschlüsse und Gewindebolzen)
R	Resistance	Widerstand
R _{ins}	Insulation resistance	Isolationswiderstand
R _{symm}	Balancing resistance	Symmetrierwiderstand
T	Temperature	Temperatur
ΔT	Temperature difference	Temperaturdifferenz
T _A	Ambient temperature	Umgebungstemperatur
T _B	Capacitor base temperature	Temperatur des Gehäusebodens
T _C	Case temperature	Gehäusetemperatur
t	Time	Zeit
Δt	Period	Zeitraum
t _b	Service life (operating hours)	Brauchbarkeitsdauer (Betriebszeit)
V	Voltage	Spannung
V _F	Forming voltage	Formierspannung
V _{op}	Operating voltage	Betriebsspannung
V _R	Rated voltage, DC voltage	Nennspannung, Gleichspannung
V _S	Surge voltage	Spitzenspannung
X _C	Capacitive reactance	Kapazitiver Blindwiderstand

Symbol	English	German
X_L	Inductive reactance	Induktiver Blindwiderstand
Z	Impedance	Scheinwiderstand
Z_T	Impedance at temperature T	Scheinwiderstand bei Temperatur T
$\tan \delta$	Dissipation factor	Verlustfaktor
λ	Failure rate	Ausfallrate
ϵ_0	Absolute permittivity	Elektrische Feldkonstante
ϵ_r	Relative permittivity	Dielektrizitätszahl
ω	Angular frequency; $2 \cdot \pi \cdot f$	Kreisfrequenz; $2 \cdot \pi \cdot f$

Note:

All dimensions are given in mm.

The following applies to all products named in this publication:

- 1 Some parts of this publication contain **statements about the suitability of our products for certain areas of application**. These statements are based on our knowledge of typical requirements that are often placed on our products in the areas of application concerned. We nevertheless expressly point out **that such statements cannot be regarded as binding statements about the suitability of our products for a particular customer application**. As a rule we are either unfamiliar with individual customer applications or less familiar with them than the customers themselves. For these reasons, it is always ultimately incumbent on the customer to check and decide whether a product with the properties described in the product specification is suitable for use in a particular customer application.
- 2 We also point out that **in individual cases, a malfunction of electronic components or failure before the end of their usual service life cannot be completely ruled out in the current state of the art, even if they are operated as specified**. In customer applications requiring a very high level of operational safety and especially in customer applications in which the malfunction or failure of an electronic component could endanger human life or health (e.g. in accident prevention or life-saving systems), it must therefore be ensured by means of suitable design of the customer application or other action taken by the customer (e.g. installation of protective circuitry or redundancy) that no injury or damage is sustained by third parties in the event of malfunction or failure of an electronic component.
- 3 **The warnings, cautions and product-specific notes must be observed.**
- 4 In order to satisfy certain technical requirements, **some of the products described in this publication may contain substances subject to restrictions in certain jurisdictions (e.g. because they are classed as hazardous)**. Useful information on this will be found in our Material Data Sheets on the Internet (www.tdk-electronics.tdk.com/material). Should you have any more detailed questions, please contact our sales offices.
- 5 We constantly strive to improve our products. Consequently, **the products described in this publication may change from time to time**. The same is true of the corresponding product specifications. Please check therefore to what extent product descriptions and specifications contained in this publication are still applicable before or when you place an order.
We also **reserve the right to discontinue production and delivery of products**. Consequently, we cannot guarantee that all products named in this publication will always be available. The aforementioned does not apply in the case of individual agreements deviating from the foregoing for customer-specific products.
- 6 Unless otherwise agreed in individual contracts, **all orders are subject to our General Terms and Conditions of Supply**.
- 7 **Our manufacturing sites serving the automotive business apply the IATF 16949 standard**. The IATF certifications confirm our compliance with requirements regarding the quality management system in the automotive industry. Referring to customer requirements and customer specific requirements ("CSR") TDK always has and will continue to have the policy of respecting individual agreements. Even if IATF 16949 may appear to support the acceptance of unilateral requirements, we hereby like to emphasize that **only requirements mutually agreed upon can and will be implemented in our Quality Management System**. For clarification purposes we like to point out that obligations from IATF 16949 shall only become legally binding if individually agreed upon.

Important notes

- 8 The trade names EPCOS, CarXield, CeraCharge, CeraDiode, CeraLink, CeraPad, CeraPlas, CSMP, CTVS, DeltaCap, DigiSiMic, FilterCap, FormFit, InsuGate, LeaXield, MediPlas, MiniBlue, MiniCell, MKD, MKK, ModCap, MotorCap, PCC, PhaseCap, PhaseCube, PhaseMod, PhiCap, PiezoBrush, PlasmaBrush, PowerHap, PQSine, PQvar, SIFERRIT, SIFI, SIKOREL, SilverCap, SIMDAD, SiMic, SIMID, SineFormer, SIOV, SurfIND, ThermoFuse, WindCap, XieldCap are **trademarks registered or pending** in Europe and in other countries. Further information will be found on the Internet at www.tdk-electronics.tdk.com/trademarks.

Release 2024-02